

# USER'S OPERATING MANUAL FOR DIGITAL TEMPERATURE CONTROLLER

(Models: AI 5441 / 5741 / 5841 / 5941)



**AI - 5441**  
(48 X 48)



**AI - 5841**  
(48 X 96)



**AI - 5741**  
(72 X 72)



**AI - 5941**  
(96 X 96)

## SPECIFICATIONS: -

1. **DISPLAY TYPE** : 4-Digit 7 segment LED (Bright White)

Model No.	AI-5441	AI-5841	AI-5741	AI-5941
Display Height	0.36"	0.56"	0.56"	0.56"

**STATUS LED'S** : OP 1 : Main Control Output

## 2. INPUT

Sensor Input : TC:J,K,R,S & RTD: Pt-100

Range : Refer below table

Sensor Type	Range	Resolution	Accuracy
Fe-k(J) T/C	0 ~ 760°C	1 °C	± 1 °C
Cr-AL(K) T/C	-99 ~ 1300°C	1 °C	
(R) T/C	0 ~ 1700°C	1 °C	
(S) T/C	0 ~ 1700°C	1 °C	
Pt-100(RTD)	-100 ~ 450°C	1 °C	± 0.3 °C
Pt-100(RTD 0.1)	-99.9 ~ 450.0°C	0.1 °C	

Sampling Time : 125 msec.

Resolution : 1°C/0.1°C(Only for RTD)

C/J for TC : Built in automatic

LWC for Pt-100 : Built in upto 18E max.

Digital Filter : 1 to 10 Sec.

## 3. RELAY OUTPUT

Contact Type : N/O, CM, N/C

Contact Rating : 5A @ 250VAC or 30 VDC

Life Expectancy : > 5,00,000 operations

Isolation : Inherent

## 4. SSR DRIVE OUTPUT

Drive Capacity : 12V @ 30mA.

Isolation : Non-Isolated.

## 5. FUNCTION

Output 1 : Main Control output

Control Action : ON-OFF/T.P (user selectable)

Control Mode : Heat/Cool (user selectable)

Compliance : ----

## 6. ENVIRONMENTAL

Operating Range : 0 ~50°C, 5~90% Rh

Storage Humidity : 95% Rh (Non-condensing)

## 7. POWER SUPPLY

Supply Voltage : 90~270VAC, 50/60Hz.

Consumption : 4W Maximum.

## 8. PHYSICAL

Housing : ABS Plastic.

Model No.	AI-5441	AI-5841	AI-5741	AI-5941
Weight (gms.)	130	200	200	240

## SAFETY INSTRUCTION :

This controller is meant for temperature control applications. It is important to read the manual prior to installing or commissioning of controller. All safety related instructions appearing in this manual must be followed to ensure safety of the operating personnel as well as the instrument.

## GENERAL

- ❖ The controller must be configured correctly for intended operation. Incorrect configuration could result in damage to the equipment or the process under control or it may lead to personnel injury.
- ❖ The controller is generally part of control panel and in such a case the terminals should not remain accessible to the user after installation.

## MECHANICAL

- ❖ The Controller in its installed state must not come in close proximity to any corrosive/combustible gases, caustic vapors, oils, steam or any other process by-products.
- ❖ The Controller in its installed state should not be exposed to carbon dust, salt air, direct sunlight or radiant heat
- ❖ Ambient temperature and relative humidity surrounding the controller must not exceed the maximum specified limit for proper operation of the controller.
- ❖ The controller in its installed state must be protected against excessive electrostatic or electromagnetic interferences. Ventilation slits provided on the chassis of the instrument are meant for thermal dissipation hence should not be obstructed in the panel.

## ELECTRICAL

- ❖ The controller must be wired as per wiring diagram & it must comply with local electrical regulation.
- ❖ Care must be taken not to connect AC supplies to low voltage sensor input.
- ❖ Circuit breaker or mains s/w with fuse (275V/1A) must be installed between power supply and supply terminals to protect the controller from any possible damage due to high voltage surges of extended duration.
- ❖ Circuit breaker and appropriate fuses must be used for driving high voltage loads to protect the controller from any possible damage due to short circuit on loads.
- ❖ To minimize pickup of electrical noise, the wiring for low voltage DC and sensor input must be routed away from high current power cables. Where it is impractical to do so, use shielded ground at both ends.
- ❖ The controller should not be wired to a 3-Phase supply with unearthed star connection. Under fault condition such supply could rise above 264 VAC which will damage the controller.
- ❖ The Electrical noise generated by switching inductive loads might create momentary Fluctuation in display, alarm latch up, data loss or permanent damage to the instrument. To reduce this use snubber circuit across the load.
- ❖ It is essential to install a over Temp. Protection device to avoid any failure of heating system. Apart from spoiling the product, this could damage the process being controlled.

**⚠ CAUTION:** To prevent the risk of electrical shock, switch off the power before making/removing any connection or removing the controller from its enclosure.

## MECHANICAL INSTALLATION

The label on the controller identifies the serial number, wiring connections and batch number.

### OVER ALL DIMENSIONS & PANEL CUT OUT (IN MM)

MODEL:-AI-5441/5741/5941

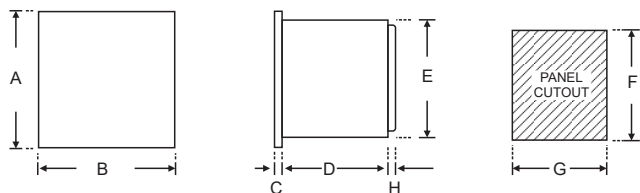
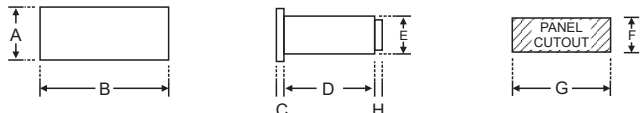

TABLE : 1

Dim Model	A	B	C	D	E	F	G	H
AI-5441	48	48	8	75	43	44	44	9
AI-5741	72	72	10	65	66	68	68	9
AI-5941	96	96	10	45	89	92	92	9
AI-5841	48	96	10	45	43	44	92	9

MODEL : AI - 5841



### INSTALLATION GUIDELINES

1. Prepare the cut-out with proper dimension as shown in figure.
2. Remove clamp from controller
3. Push the controller through panel cut-out and secure the controller in its place by tightening the side clamp.

### ELECTRICAL INSTALLATION

The electrical connection diagram is shown on the controller enclosure as below.

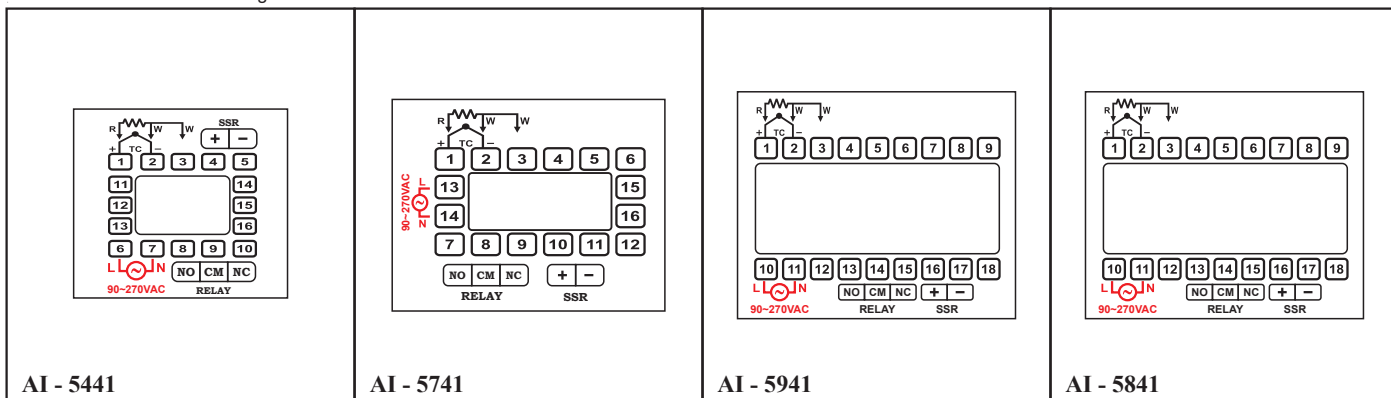

### FRONT PANEL LAYOUT

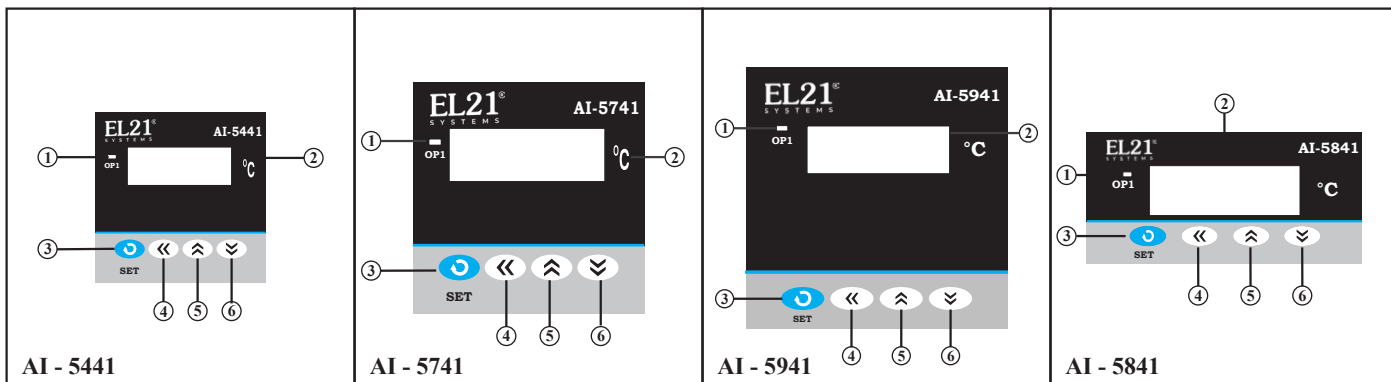

### FRONT PANEL LAYOUT DESCRIPTION :

Sr.	NAME	FUNCTION
1	OP1 LED	Glows when OP1 is ON & flashes when delay time (dly) is in operation (if selected mode is ON-OFF)
2	DISPLAY	It will display: (1) Measured value of selected input or Error messages. (2) SP (Main set point) value in run mode. (3) Parameters Value/code in program mode.
3	SET KEY	(1) For SP programming. (2) To access Control mode along with DN Key. (3) To access Configuration mode along with UP key. (4) To scroll the parameter & to store its value.
4	SHIFT KEY	(1) To increase/alter parameter value in program mode with Up / Dn Key. (2) Press for 3Sec in Programming this will help to go back to previous parameter.
5	UP KEY	(1) To increase/alter parameter value in program mode. (2) To Enter in configuration mode (with SET key) . (3) To Set SP Offset (with DOWN Key).
6	DOWN KEY	(1) To decrease/alter parameter value in program mode. (2) To Enter control mode

## PROGRAMMING

**USER LIST :** To access the user list Press & Release SET key once.

(All following selected parameter's code shown in shaded will be displayed for 1 sec. followed by their values / options)

PARA METER	DISPLAY	RANGE	DESCRIPTION	DEFAULT
CONTROL SET POINT	<b>SP</b> > <input type="text" value="0"/>	LSPL ~ HSPL	User can change SP value using UP/ DOWN keys. Holding the key, will change the value at a faster rate. Press SET key to store the value & move on to next parameter.	0°C

**CONTROL LIST :** To enter in this mode, press SET & DOWN key simultaneously for 3 sec. User can then set all the control related parameters as shown below.

(All following selected parameter's code shown in shaded will be displayed for 1 sec. followed by their values / options)

PARA METER	DISPLAY	RANGE	DESCRIPTION	DEFAULT
LOCK CODE	<b>LOCK</b> > <input type="text" value="0"/>	1 ~ 9999	Set this parameter to 15 (Default LOCK CODE) to access Control List. User has a choice to set different Lock Code via USER LOCK CODE in Config. List.	0
P.BAND	<b>P.bnd</b> > <input type="text" value="5.0"/>	0.5 to 999.9 °C	This parameter will appear only if selected control action is T.P. It sets bandwidth over which the output power is adjusted depending upon the error (SV-PV).	5.0°C
CYCLE TIME	<b>CYCL</b> > <input type="text" value="16.0"/>	1.0 to 100.0 °C	This parameter will appear only if selected control action is T.P. User can set this value based on process being controlled & type of output being selected. For Relay O/P, cycle time should be more than 12 Sec & for SSR O/P, cycle time should be less than 5 Sec.	16.0 Sec.
CONTROL HYS.	<b>HYSI</b> > <input type="text" value="2"/>	1 to 100°C	This parameter will appear only if selected control action is ON-OFF. It sets the dead band between ON & OFF switching of the Output. Larger value of hysteresis minimize the number of ON-OFF operation of the load. This increases life of actuators like Relay but, also produces large errors.	2°C
DELAY	<b>DLYI</b> > <input type="text" value="0"/>	0 to 500 Sec.	This parameter will appear only if selected control action is ON-OFF. It sets the main output restart time. If set to '0', O/P will be switched without delay. Also, Delay will be considered in case of every power ON.	0 Sec.
MANUAL OFF SET	<b>SPDF</b> > <input type="text" value="0"/>	-25 to 25 °C	This parameter will appear only if selected C.A is time proportional. (For more details refer User guide.)	0 °C

**CONFIGURATION LIST :** (1) To enter in this mode, Press and hold SET & UP key simultaneously for 3 sec.

(2) Press UP or DOWN key to scroll between parameter options.

(3) Press SET key to store the current parameter & move on to the next parameter.

(All following selected parameter's code shown in shaded will be displayed for 1 sec. followed by their values / options)

PARA METER	DISPLAY	DESCRIPTION	DEFAULT																								
LOCK CODE	<b>LOCK</b> > <input type="text" value="0"/>	Set this parameter to 15 (Default LOCK CODE) to access Config. List. User has a choice to set different Lock Code in the range 1 ~ 9999 via USER LOCK CODE in Config. List.	0																								
INPUT TYPE	<b>INPT</b> > <input type="text" value="tC-J"/> ↓ ↑ <input type="text" value="tC-P"/> ↓ ↑ <input type="text" value="tC-r"/> ↓ ↑ <input type="text" value="tC-S"/> ↓ ↑ <input type="text" value="rtd"/> ↓ ↑ <input type="text" value="rtd1"/>	This parameter value is set according to the type of sensor (Thermocouple or RTD Input) connected to the Controller's Input Terminals. <table border="1" style="margin-top: 10px;"> <thead> <tr> <th>Sensor Type</th> <th>Range</th> <th>Resolution</th> <th>Accuracy</th> </tr> </thead> <tbody> <tr> <td>Fe-k(J) T/C</td> <td>0 ~ 760°C</td> <td>1 °C</td> <td rowspan="4">} ± 1 °C</td> </tr> <tr> <td>Cr-AL(K) T/C</td> <td>-99 ~ 1300°C</td> <td>1 °C</td> </tr> <tr> <td>(R) T/C</td> <td>0 ~ 1700°C</td> <td>1 °C</td> </tr> <tr> <td>(S) T/C</td> <td>0 ~ 1700°C</td> <td>1 °C</td> </tr> <tr> <td>Pt-100(RTD)</td> <td>-100 ~ 450°C</td> <td>1 °C</td> <td rowspan="2">} ± 0.3 °C</td> </tr> <tr> <td>Pt-100(RTD 0.1)</td> <td>-99.9 ~ 450.0°C</td> <td>0.1 °C</td> </tr> </tbody> </table>	Sensor Type	Range	Resolution	Accuracy	Fe-k(J) T/C	0 ~ 760°C	1 °C	} ± 1 °C	Cr-AL(K) T/C	-99 ~ 1300°C	1 °C	(R) T/C	0 ~ 1700°C	1 °C	(S) T/C	0 ~ 1700°C	1 °C	Pt-100(RTD)	-100 ~ 450°C	1 °C	} ± 0.3 °C	Pt-100(RTD 0.1)	-99.9 ~ 450.0°C	0.1 °C	tC-J
Sensor Type	Range	Resolution	Accuracy																								
Fe-k(J) T/C	0 ~ 760°C	1 °C	} ± 1 °C																								
Cr-AL(K) T/C	-99 ~ 1300°C	1 °C																									
(R) T/C	0 ~ 1700°C	1 °C																									
(S) T/C	0 ~ 1700°C	1 °C																									
Pt-100(RTD)	-100 ~ 450°C	1 °C	} ± 0.3 °C																								
Pt-100(RTD 0.1)	-99.9 ~ 450.0°C	0.1 °C																									
LOWER SP LIMIT	<b>LSPL</b> > <input type="text" value="0"/>	Sets the minimum limit for set point adjustment. It can be set from minimum specified range of selected sensor to HSPL value.	0 °C																								
HIGHER SP LIMIT	<b>HSPL</b> > <input type="text" value="400"/>	Sets the maximum limit for set point adjustment. It can be set from LSPL value to maximum specified range of selected sensor.	400 °C																								
PROCESS VALUE OFFSET	<b>OFSE</b> > <input type="text" value="0"/>	Function of this parameter is to add/subtract a constant value to the measured PV to obtain Final PV for control applications. This parameter value needs to be altered for one of the following reason : (i) To compensate for known thermal gradient. (ii) To match the display values with another recorder or indicator measuring the same PV.	0 °C																								

